

1.) Verschlussplatte entfernen,
Dichtring aushebeln und entfernen.

Remove closing plate, lever out and remove
seal.

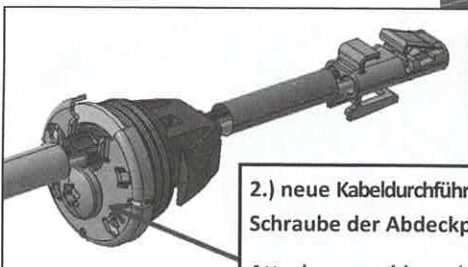

2.) neue Kabeldurchführung anstecken +
Schraube der Abdeckplatte ca. 2. Umdrehungen lösen.

Attach new cable and loosen the closing plate screw approx. two

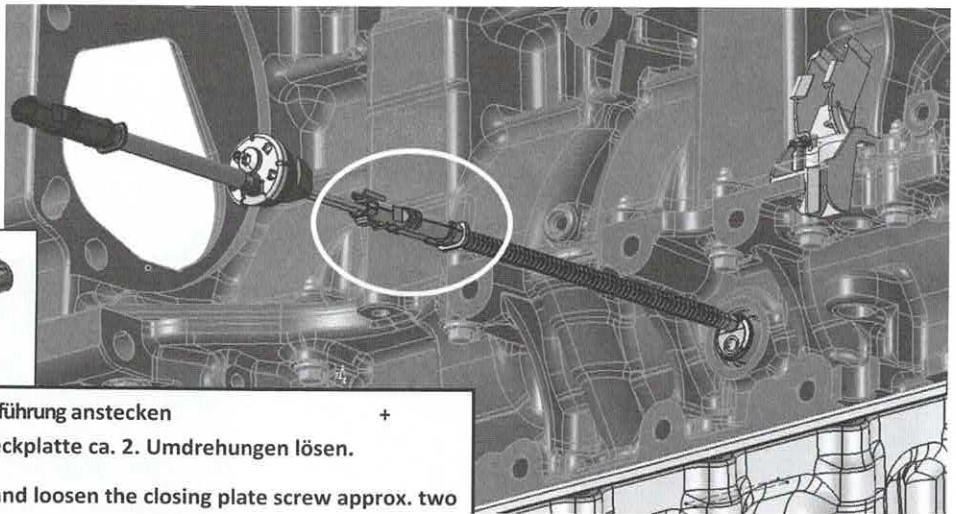

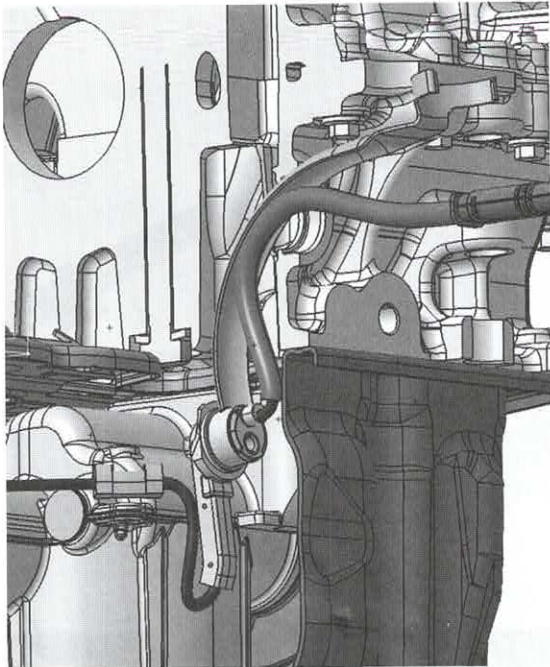

3.) Einschieben der alten Kabeldurchführung mittels Hilfswerkzeug bis tiefstmöglicher Lage, dabei Nachführen der neuen Durchführung inklusive Steckverbindung.

Insert the old cable to the lowest possible position using the tool provided. Followed by the new cable and connector.

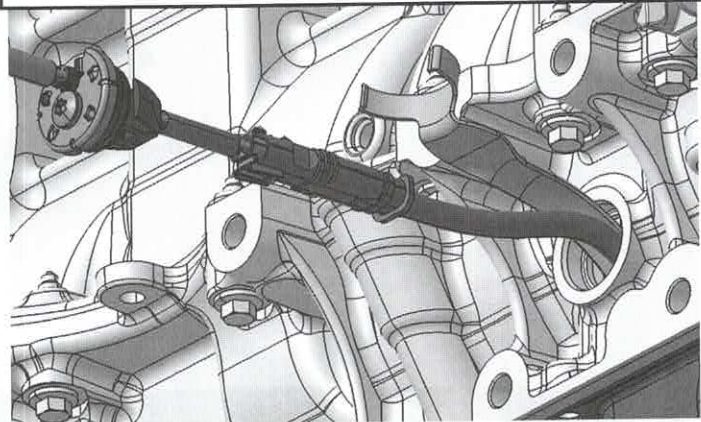

4.) Eindrücken der neuen Kabeldurchführung bis diese spürbar einrastet.

Push the new cable and overmoulding until it clicks noticeably into place.

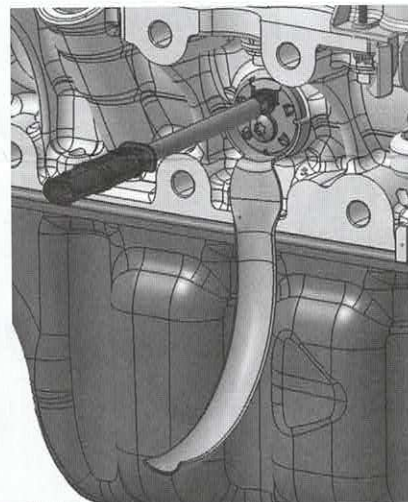

5.) Anziehen der Verschlussplatte mit 4Nm , Gegenhalten mit Gabelschlüssel in den Ausklüngen am Umfang

Tighten the closing plate fixing to 4Nm whilst using the tool in the notches on the periphery to resist the rotation.

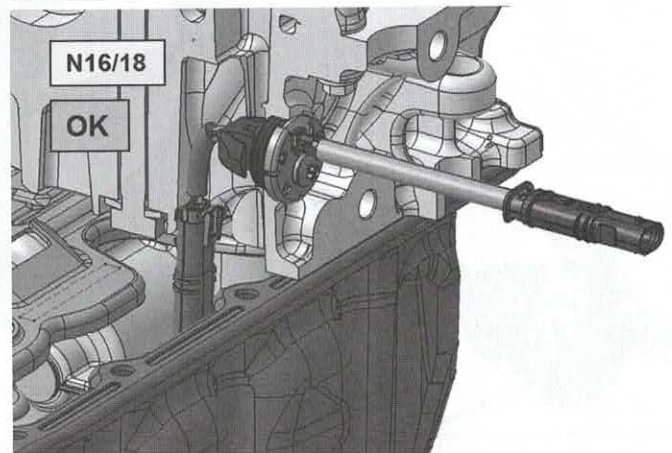
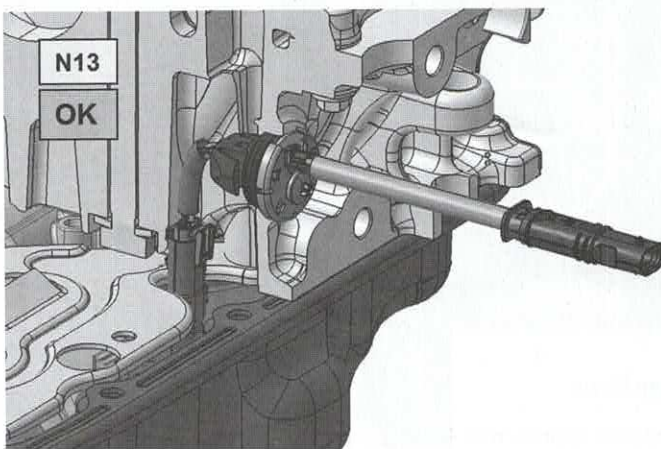

Achtung, wichtige Hinweise für N13 —> Ölhobelblech behindert Einführvorgang !

Attention: important information for N13 —> oil baffle-plate hampers insertion !

- 1.) alte Kabeldurchführung / old cable.
- 2.) Hilfswerkzeug / Additional Service Tool.
- 3.) Steckergehäuse / Connector housing.

